

ASSEMBLY INSTRUCTIONS

3 CABLE PENDANT

DANGER – RISK OF SHOCK – DISCONNECT POWER BEFORE INSTALLATION

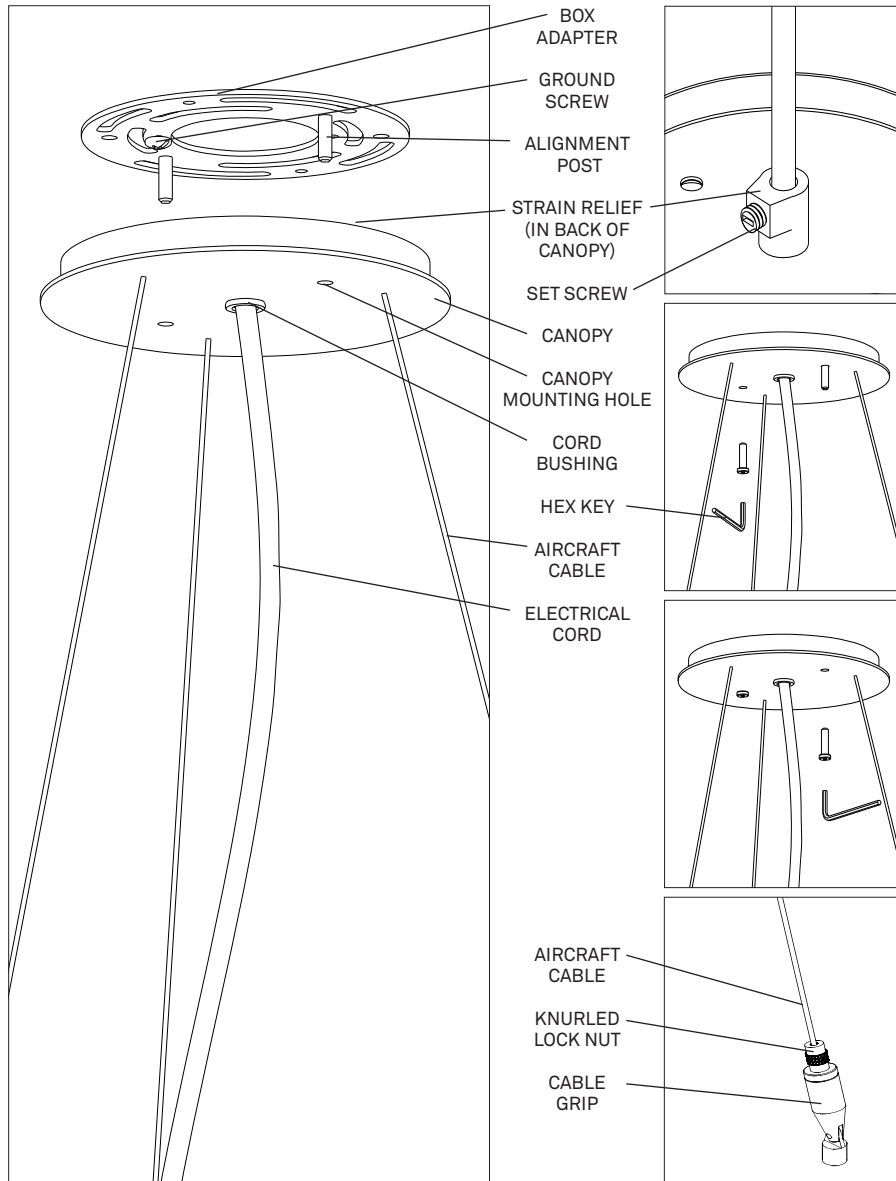

1. Determine the drop of the fixture. Trim electrical cord to the appropriate length. Allow for some slack in the cord. It should not be pulled tight. Allow 6" of additional cord/leads inside the j-box.
2. When the appropriate length of electrical cord has been determined, gently tighten the set screw on the strain relief on the inside face of the canopy allowing 6" of leads as noted above. Make the electrical connections in the j-box with the weight of the fixture supported.

REFERENCE THE WIRING DIAGRAM THAT MATCHES THE TYPE OF DRIVER INSTALLED IN THE FIXTURE

3. The j-box adapter will be shipped with locating studs threaded into it. The canopy assembly will be shipped with aircraft cables in place. Slip the canopy assembly over the locating studs. One after the other, unthread the locating studs and replace them with mounting screws.

BE CAREFUL THAT SUPPORT CABLES DO NOT CROSS EACH OTHER (GET TANGLED).

4. Loosen knurled lock nuts on the cable grips. Push the lock nut in to release, and feed the aircraft cables through the cable grip. Adjust shade to level and trim excess aircraft cable. Tighten knurled lock nuts.

RESOLUTE

RESOLUTE is a registered trademark of MANIFESTO corporation
4617 Colorado Avenue South, Unit A, Seattle WA 98134
www.resoluteonline.com info@resoluteusa.com



WIRING DIAGRAMS

TRIAC/PHASE CONTROL 1% Dimming

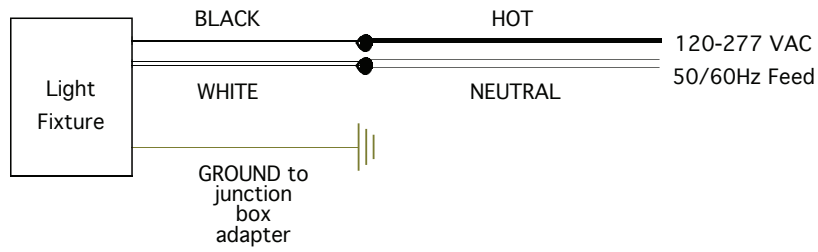

Wiring Diagram for EcoSystem Digital Control

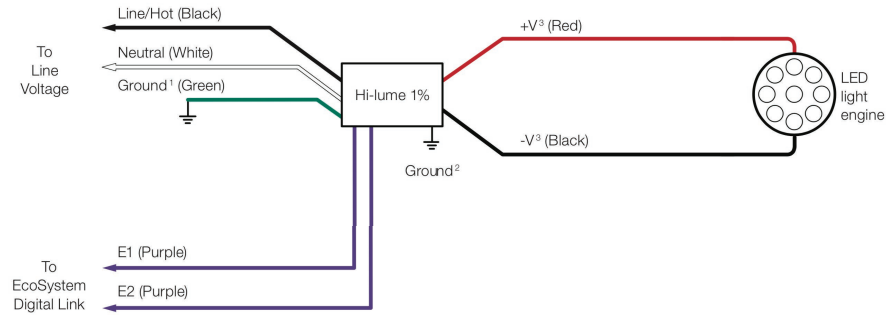

0-10V Dimming

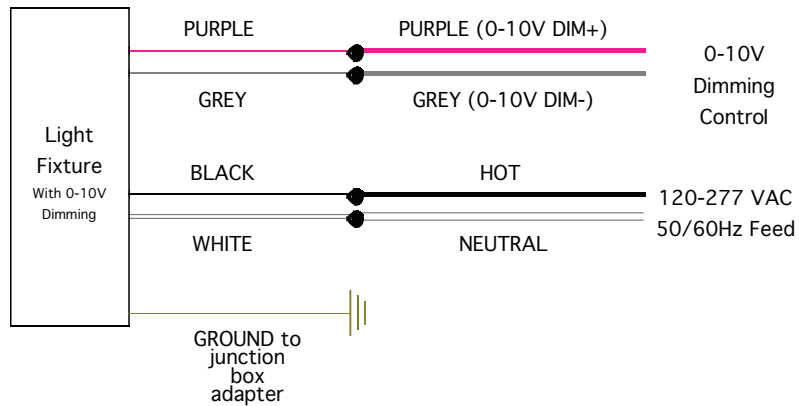

Wiring Diagram

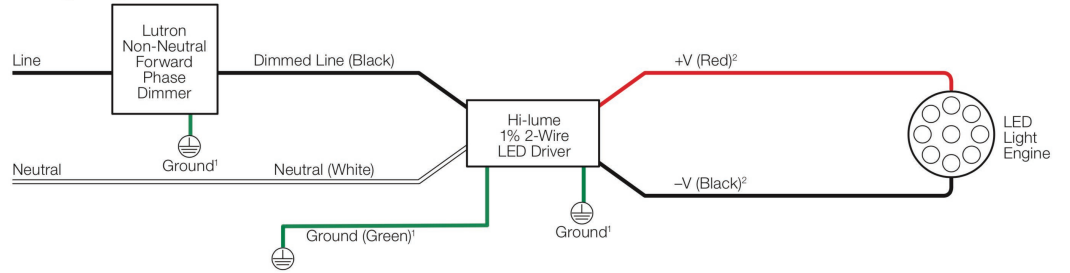

Wiring Diagram

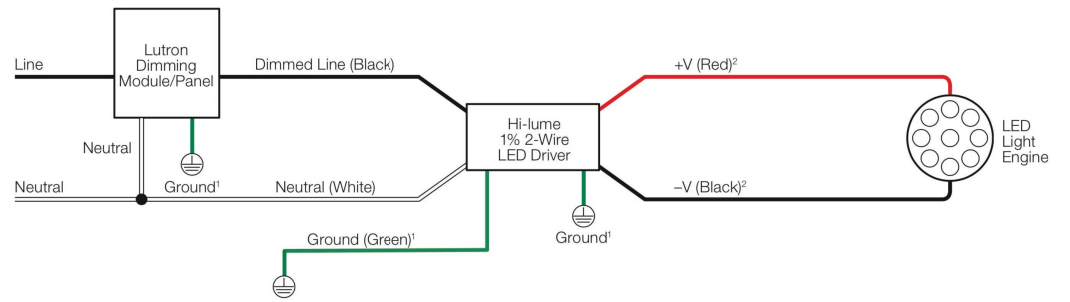

RESOLUTE

RESOLUTE is a registered trademark of MANIFESTO corporation
4617 Colorado Avenue South, Unit A, Seattle WA 98134
www.resoluteonline.com info@resoluteusa.com

